

18	GEAR OPERATOR W/ AWWA 2" NUT	
17	LIFTING EYES	SS304
16	HEX BOLT	SS304
15	WASHER	SS304
14	YOKE	ASTM A536 65-45-12
13	O-RINGS	EPDM
12	THRUST BEARINGS	ASTM B16
11	BUSHING	ASTM B16
10	O-RING	EPDM
9	COVER	ASTM A536 65-45-12
8	COVER SEAL	EPDM
7	HEX BOLT	SS304
6	WASHER	SS304
5	HEX NUT	SS034
4	STEM	ASTM A276 304
3	STEM NUT	ASTM B16
2	WEDGE	ASTM A536 + EPDM
1	BODY	ASTM A536 65-45-12
NO	NAME	MATERIAL

### Design Specification

Design confirm to AWWA C509/C515  
Connections confirm to C111/A21.11  
Face to face confirm to ASME B16.10  
Pressure Rating: Class 150/Class 250

30" C509/C515 NRS Gate Valve (MjxMJ)



DWG NO. 30NRMGV

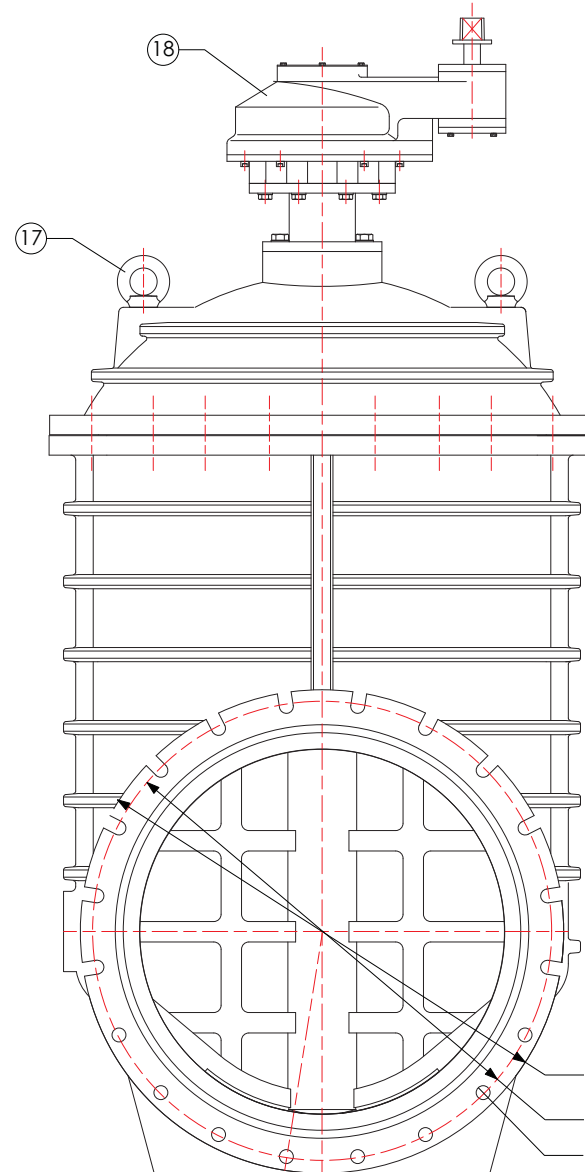
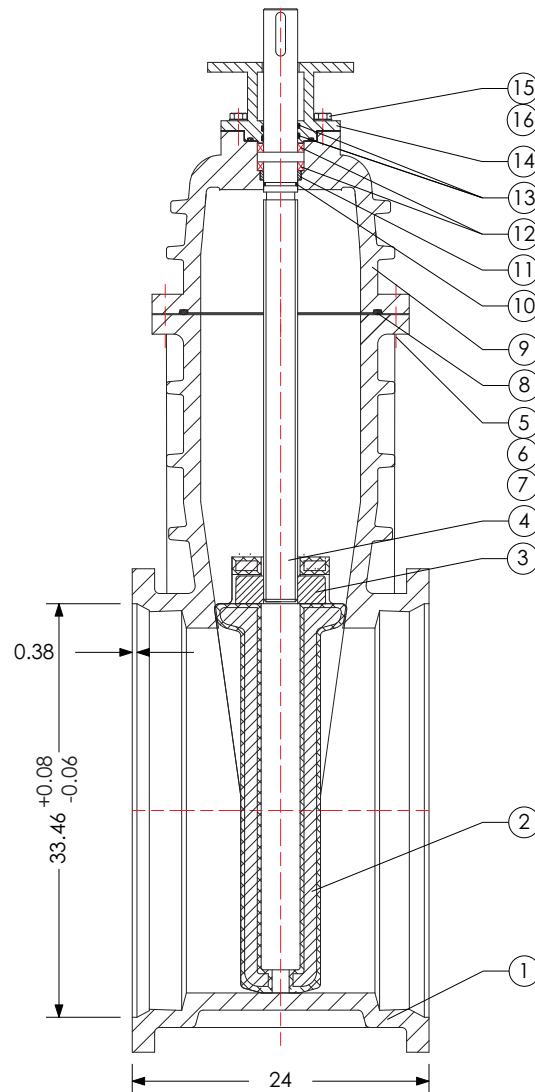

Ø39.12 +1.00  
-0.18

36.88

20 X 1/8 THRU