

Remark: The valves will be operated by Bevel or Spur gear box

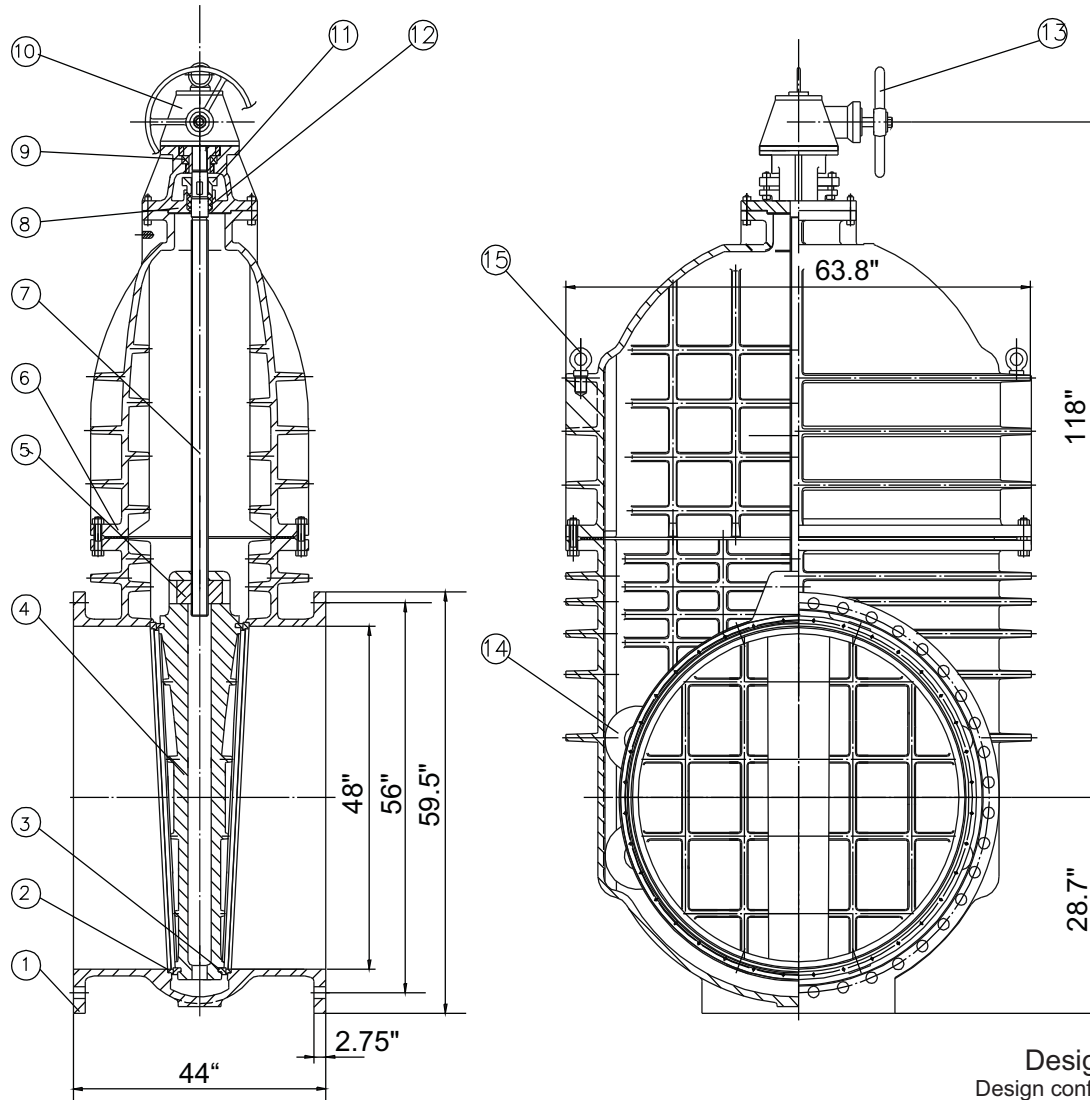

ITEM	COMPONENT	MATERIAL
1	BODY	DUCTILE IRON TO ASTM A536
2	GATE RING	BRONZE TO ASTM B148
3	BODY RING	BRONZE TO ASTM B148
4	GATE	DUCTILE IRON TO ASTM A536
5	STEM NUT	BRONZE TO ASTM B148
6	BONNET	DUCTILE IRON TO ASTM A536
7	STEM	STAINLESS STEEL TO ASTM A276
8	YOKE	DUCTILE IRON TO ASTM A536
9	BEARING	
10	GEARBOX	BEVEL TYPE
11	GLAND	DUCTILE IRON TO ASTM A536
12	STUFFING	GRAPHITE
13	HANDWHEEL	GREY CAST IRON TO ASTM A126, CLASS B
14	ROLLER	STAINLESS STEEL TO ASTM A276
15	EYEBOLT	CARBON STEEL

Face to face can be according to buyer's requirement.

Design Specification
 Design confirm to AWWA C500
 Connections confirm to ASME B16.1
 Face to face confirm to ASME B16.10
 Pressure Rating: Class 150/Class 250

48" C500 NRS Gate Valve (FLxFL)	
	DWG NO.48NRMMGV
	