

NO	NAME	MATERIAL
1	BODY	ASTM A536 65-45-12
2	DISC	ASTM A351 CF8M
3	SEAT	VITON
4	SPRING STEM	ASTM A276 316
5	DISC STEM	ASTM A276 316
6	SPRING	AISI 316
7	SHAFT SEAL	NBR
8	GRUB SCREW	ASTM A194 2H
9	LIFTING EYE	ASTM A489 TYPE 2

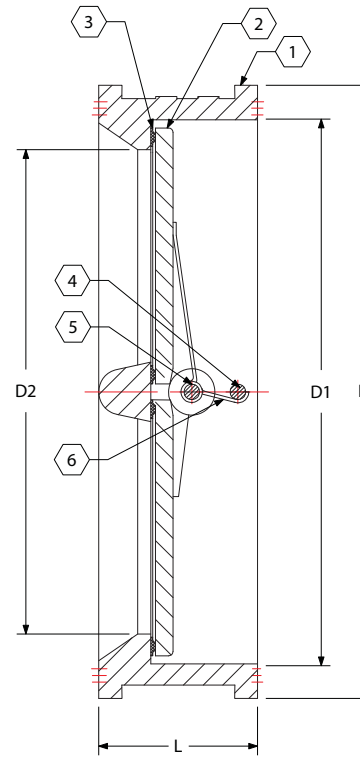

**Design Specification**  
 Design confirm to AWWA C518  
 Connections confirm to ASME B16.1  
 Face to face confirm to ASME B16.10  
 Pressure Rating: Class 150/Class 250

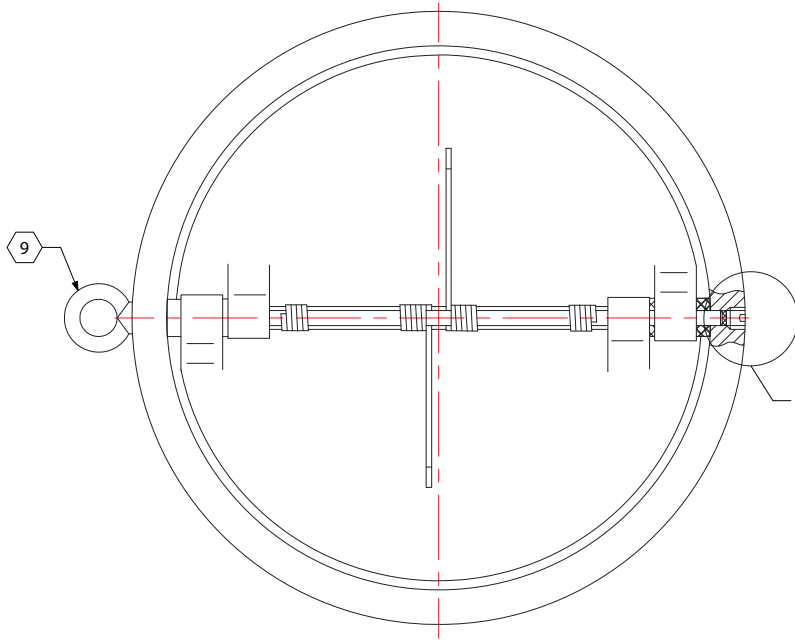

DN	NPS	L	D	D1	D2
50	2	2.125	4.0	2.6	1.8
65	2.5	2.375	5.8	3.1	2.4
80	3	2.625	5.2	3.7	2.8
100	4	2.625	6.8	4.6	3.5
125	5	3.250	7.4	5.7	4.5
150	6	3.750	8.6	6.7	5.3
200	8	5.000	10.9	8.7	7.2
250	10	5.500	13.3	10.9	8.7
300	12	7.125	16.0	12.9	10.2
350	14	7.250	17.6	14.8	11.7
400	16	7.500	20.1	16.1	13.8
450	18	8.000	21.5	17.7	15.2
500	20	8.375	23.7	19.9	17.2
600	24	8.750	28.1	24.6	21.2

ENLARGE I

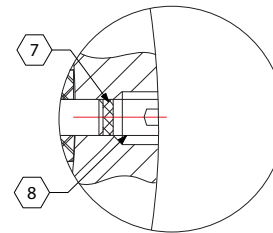

2" - 24" C518 Dual Disc Check Valve



DWG NO. B24DDCV

