

Eye bolt attached to cover
in sizes 10" & larger .

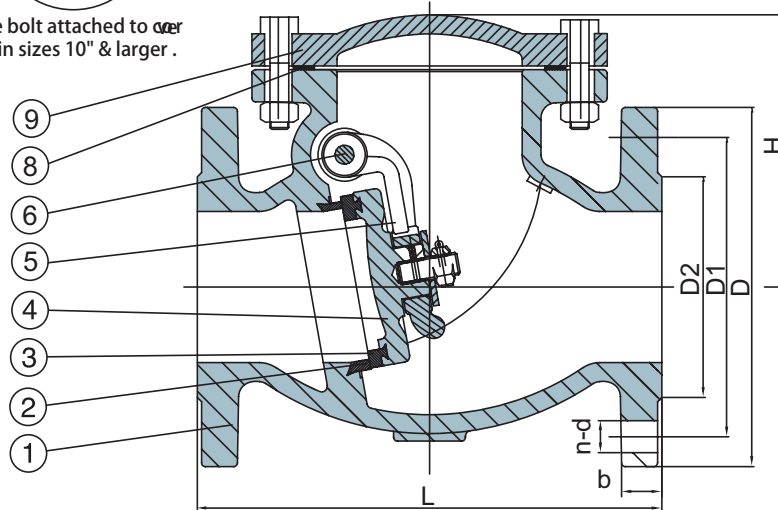

Size	L	D	D1	D2	b	n-d	H	W.T(kg)
DN40	180	150	110	84	18	4-19	110	9.0
DN50	200	165	125	99	20	4-19	130	13.4
DN65	240	185	145	118	20	4-19	140	17.7
DN80	260	200	160	132	22	8-19	150	20.8
DN100	300	220	180	156	24	8-19	160	29.3
DN125	350	250	210	184	26	8-19	190	47.0
DN150	400	285	240	211	26	8-23	210	67.0
DN200	500	340	295	266	30	12-23	250	118.7
DN250	600	405	355	319	32	12-28	310	171.9
DN300	700	460	410	370	32	12-28	340	232.5
DN350	800	520	470	429	36	16-28	450	330.0
DN400	900	580	525	480	38	16-31	520	460.0
DN450	1000	640	585	548	40	20-31	550	580.0
DN500	1100	715	650	609	42	20-34	590	700.0
DN600	1300	840	770	720	48	20-37	680	780.0

Item	Part Name	Material	Item	Part Name	Material
1	Body	GG25	4	Disc	GG25
2	Seat Ring	Brass	5	Hanger	GGG50
		Bronze	6	Hanger Pin	Stainless Steel
3	Disc Ring	Brass /Bronze	8	Cover Gasket	Graphite With Soft Steel
		EPDM /NBR	9	Cover	GG25

Design Specification

Connections confirm to EN1092-2
 Face to face confirm to DIN3202 F6
 Pressure Rating: PN16
 Available Option: Outside Lever and Weight
 Rubber and Metal Seat Available

DIN3202 F6 DN40-DN600 Swing Check Valve



DWG NO. B600SWCV

