

Eye bolt attached to cover
in sizes 10" & larger .

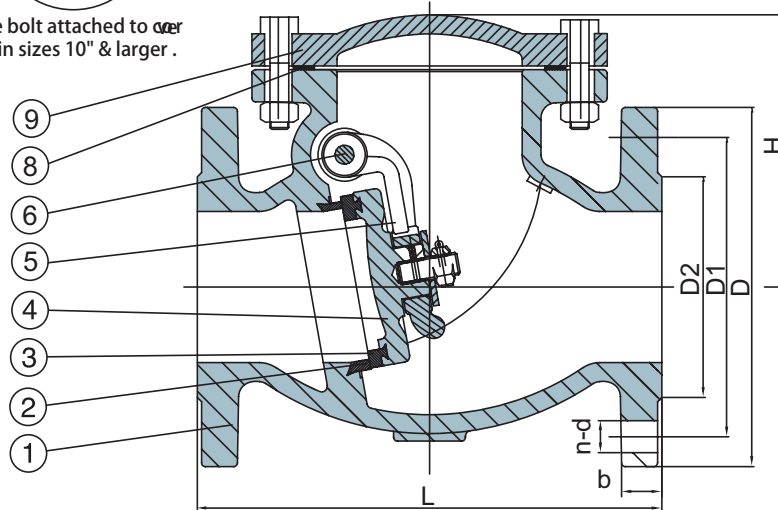

Size	L	D	D1	D2	b	n-d1	H	W.T(kg)
DN40	165	150	110	88	18	4-19	110	10.5
DN50	203	165	125	102	20	4-19	130	12.5
DN65	216	185	145	122	20	4-19	140	17.3
DN80	241	200	160	138	22	8-19	150	24.5
DN100	292	220	180	158	24	8-19	160	37.5
DN125	330	250	210	188	26	8-19	190	41
DN150	356	285	240	212	26	8-23	210	46.2
DN200	495	340	295	268	30	12-23	250	120
DN250	622	405	355	320	32	12-28	310	198
DN300	699	460	410	378	32	12-28	340	282
DN350	787	520	470	438	36	16-28	450	350
DN400	914	580	525	490	38	16-31	520	430
DN450	914	640	585	548	40	20-31	550	638
DN500	1016	715	650	610	42	20-34	590	705
DN600	1219	840	770	725	48	30-37	680	900

Item	Part Name	Material	Item	Part Name	Material
1	Body	GG25	4	Disc	GG25
2	Seat Ring	Brass	5	Hanger	GGG50
		Bronze	6	Hanger Pin	Stainless Steel
3	Disc Ring	Brass /Bronze	8	Cover Gasket	Graphite With Soft Steel
		EPDM /NBR	9	Cover	GG25

Design Specification

Connections confirm to EN1092-2
 Face to face confirm to BS5153
 Pressure Rating: PN16
 Available Option: Outside Lever and Weight
 Rubber and Metal Seat Available

BS5153 DN40-DN600 Swing Check Valve



DWG NO. B600SWCV

